

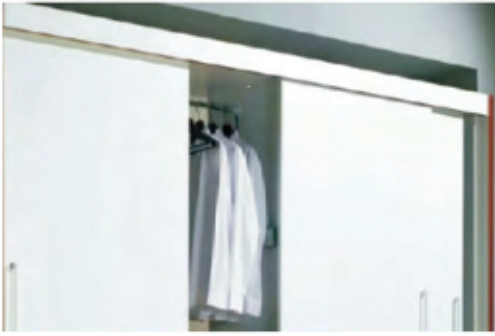

## SLIDING DOOR SYSTEMS

21 Zune Street, Magnavia, Polokwane - Tel: 015 004 0198 - Email: [heloenterprises1@gmail.com](mailto:heloenterprises1@gmail.com)

[www.fittingsforafrica.co.za](http://www.fittingsforafrica.co.za)



Sliding Door Systems are made up of a runner and the roller carriage that it carries. These move the connected sliding door leaf and any other elements. FFD offer a wide range of innovative hardware systems for these alternatives. Our range of Sliding Door Systems with different runner types permit solutions for all furniture segments, conveniently moving door elements in all sizes and materials.

### Single Plastic Track

### Double Plastic Track

CODE

**TR**

Single Track - 3.0m Lengths  
White, Black, Brown & Tan

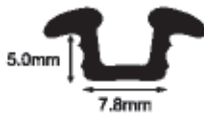
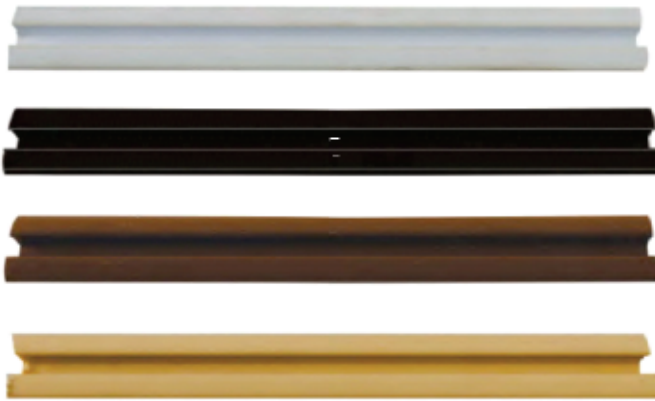

CODE

**PV003**

Top Track - 3.0m Lengths  
White, Black, Brown & Tan

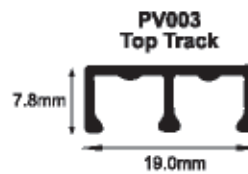

CODE

**PV004**

Bottom Track - 3.0m Lengths  
White, Black, Brown & Tan

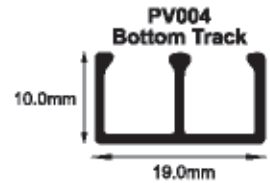

CODE  
**L603**

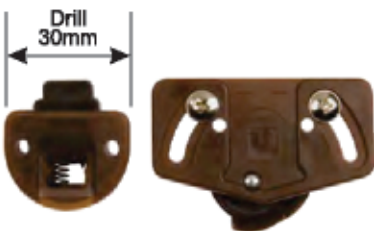

Top & Bottom (2 Piece Set)  
Nylon Wheel Brown

CODE  
**L602**

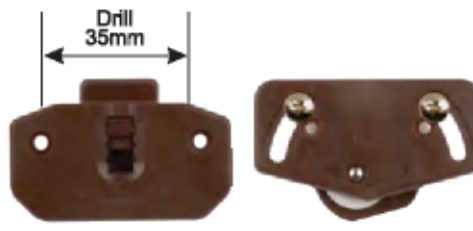

Top & Bottom (2 Piece Set)  
Nylon Wheel Brown

CODE  
**L602S**

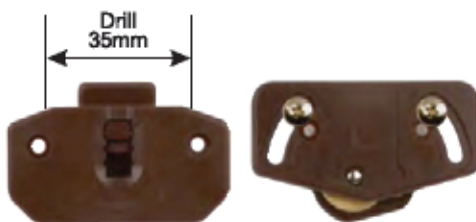

Top & Bottom (2 Piece Set)  
Brass Wheel Brown

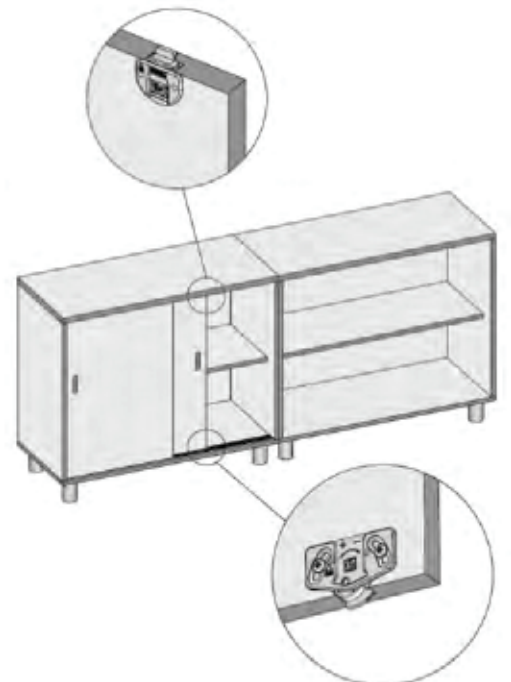

# SLIDING DOOR SYSTEMS

## Sliding Door System (Light Duty)

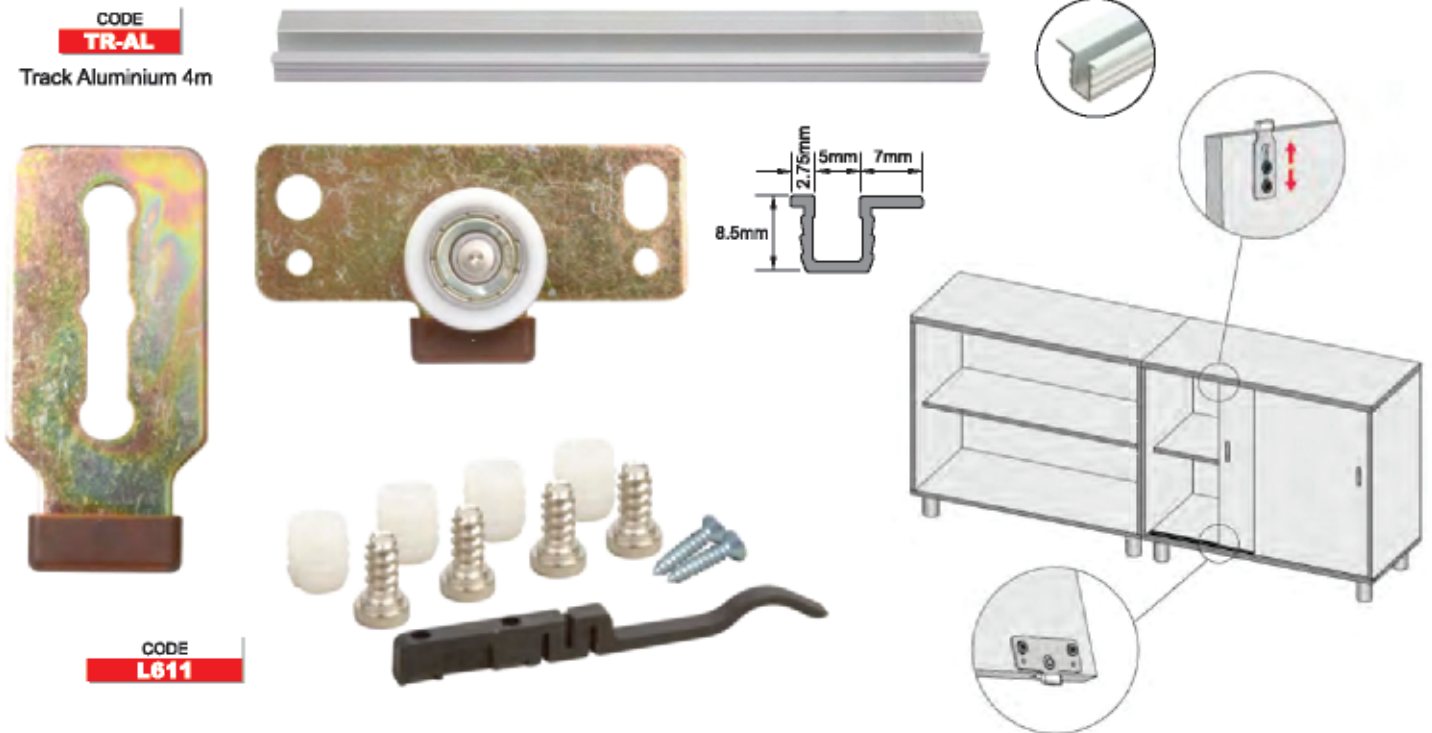

## Sliding Door System (Medium Duty)

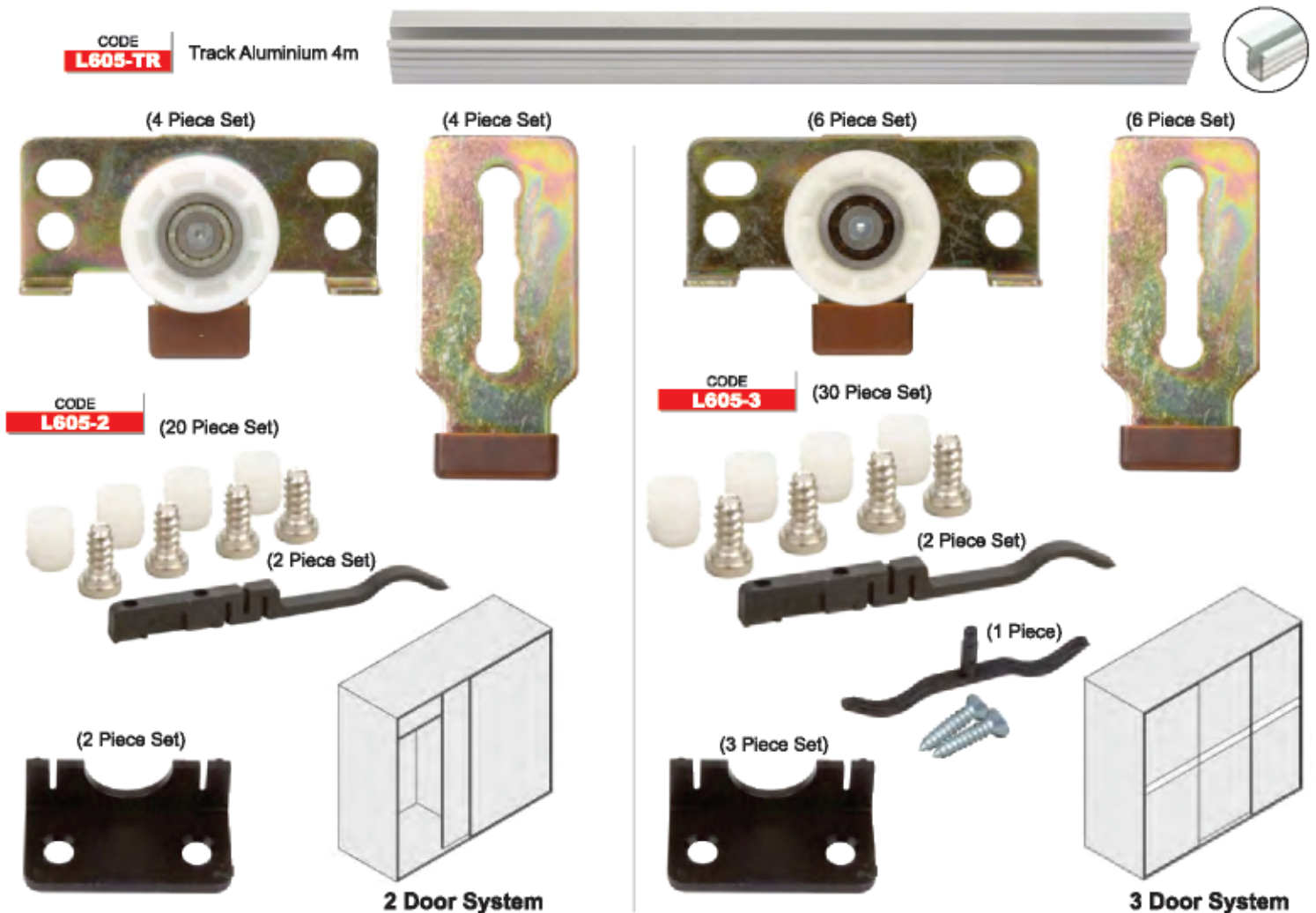

Sliding Door System (Heavy Duty)

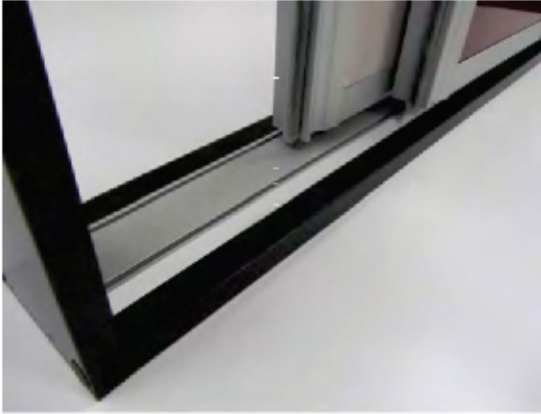

CODE  
**SDS005**  
Handle Profile  
Anodized  
2.7m Lengths



CODE  
**SDS001**  
Upper Track  
Profile  
Anodized  
Lengths Available  
3m, 4m  
(2 Pieces per Set)

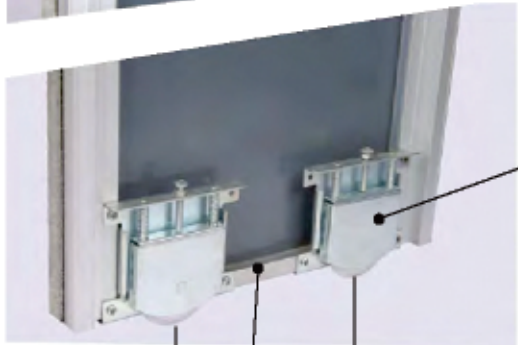
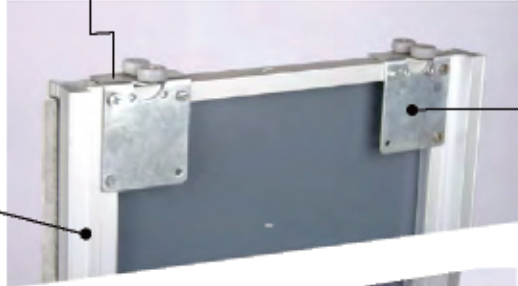

CODE  
**SDS003**  
Bottom Double  
Track Profile  
Anodized  
Available Lengths  
3m, 4m



CODE  
**SDS008**  
Sliding Door Wheel Set 4 Pieces  
(Sold 2 x Top + 2 x Bottom)  
See Below

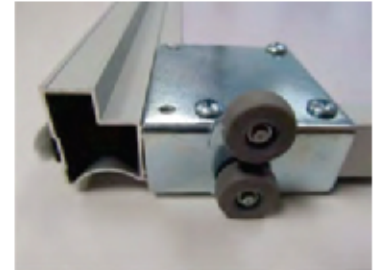

(2 Pieces per Set)



CODE  
**SDS006**  
Horizontal  
"H" Profile  
Anodized  
Available  
Length  
3m, 4m

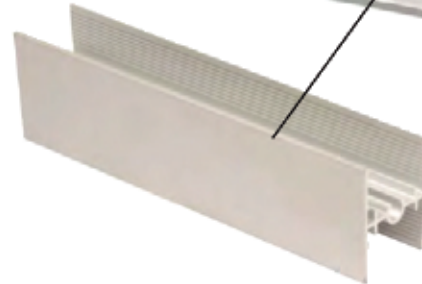

CODE  
**SDS007**  
Top & Bottom Profile  
Anodized  
Available Length  
3m, 4m



CODE  
**SDS010**  
Self Adhesive Brush  
W9xH5mm  
Sold per Metre



CODE  
**SDS009**  
Soft Close  
Mechanism Sold in Pairs  
(Left & Right)



## Aluminium Glass Door Profile System

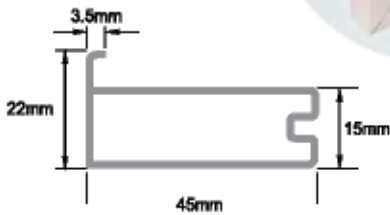

Drill standard pot holes as required

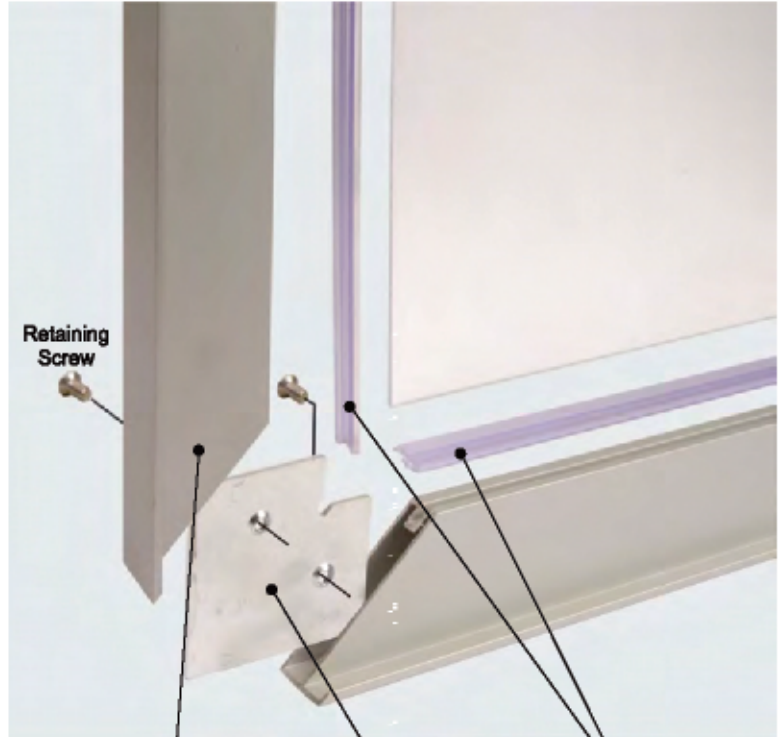

Retaining Screw

CODE  
**7916**

Aluminium Extrusion Anodized  
Available Length 3m  
(Mitre cut to size as required)

CODE  
**C5**

Corner Bracket  
Supplied with 2 Screws  
(4 Pieces per Set)

CODE  
**S8-1**

PVC Gasket  
Available Length 3m  
(Cut to size as required)

### Nail-In Glides



CODE  
**L505**

D15x1.6mm

### Screw-In Glides



CODE  
**MO97-6**

M6x20mm  
Black

CODE  
**MO97-8**

M8x25mm  
Black

CODE  
**MO97-10**

M10x25mm  
Black

### Dome Glides



CODE  
**234**

Nickel Plated

Brass Plated

D13mm

D 13mm

D16mm

D16mm

D22mm

D22mm

### Plastic Glides

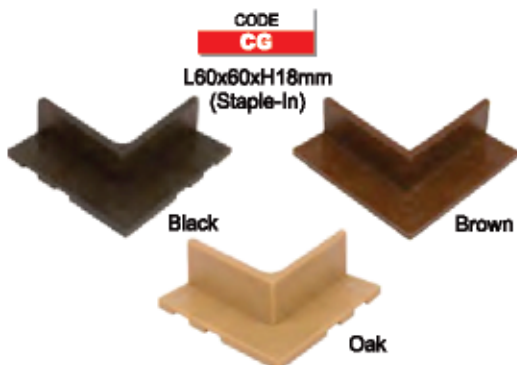

CODE  
**CG**

L60x60xH18mm  
(Staple-In)

Black

Brown

Oak



CODE  
**SG**

L40x18x12mm  
(Staple-In)

Black

CODE  
**CNR-PR**

Corner Protector  
Clear  
(Staple-In)



CODE  
**G32**

L50xW14xT3.0mm

32mm

Black or Brown

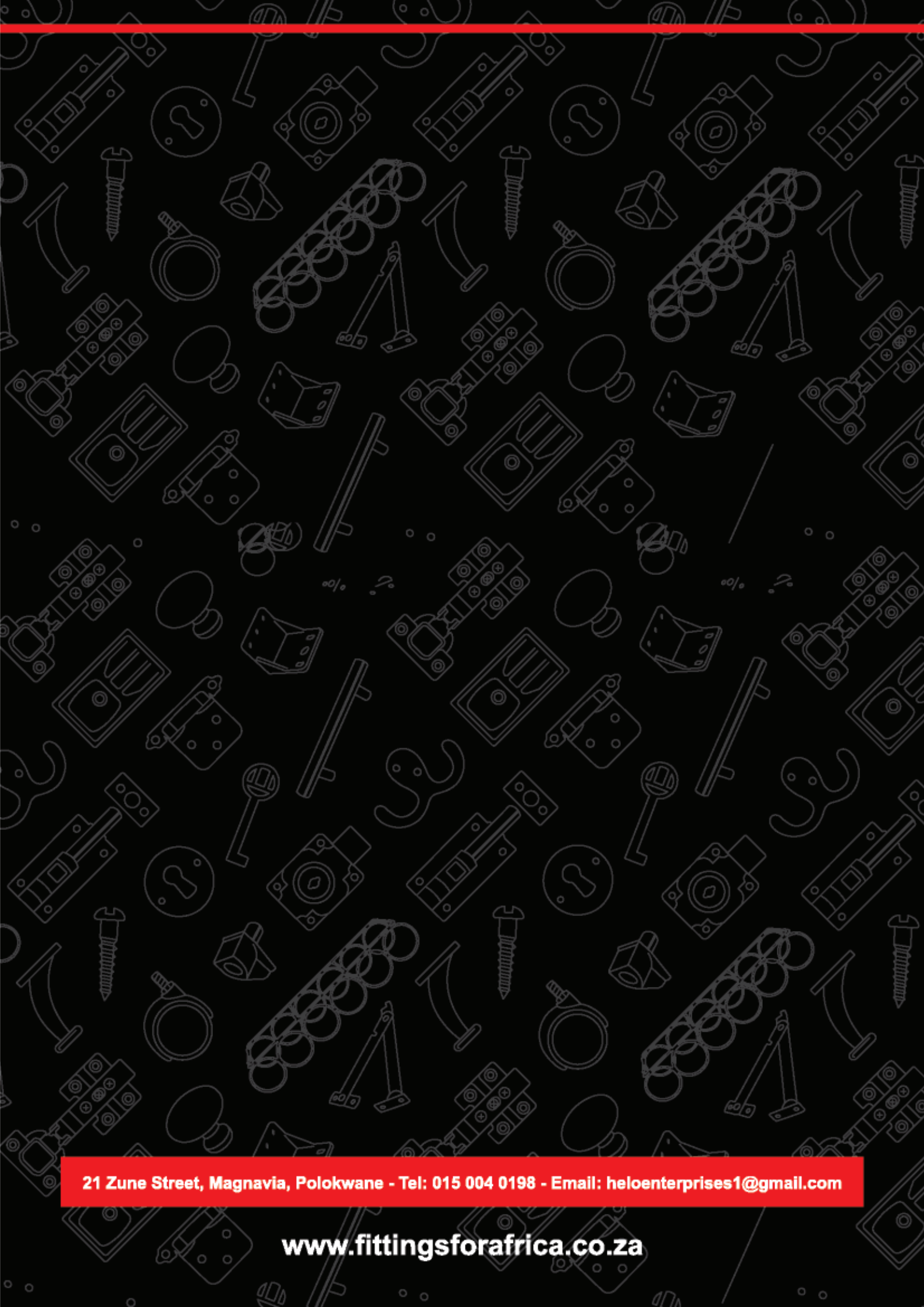

21 Zune Street, Magnavia, Polokwane - Tel: 015 004 0198 - Email: [heloenterprises1@gmail.com](mailto:heloenterprises1@gmail.com)

[www.fittingsforafrica.co.za](http://www.fittingsforafrica.co.za)